



Vestil Manufacturing Corp.

2999 North Wayne Street, P.O. Box 507, Angola, IN 46703

Telephone: (260) 665-7586 -or- Toll Free (800) 348-0868

Fax: (260) 665-1339

Web: www.vestilmfg.com e-mail: sales@vestil.com

A-LIFT Manual Winch Lift Trucks Instruction Manual



A-LIFT-S



A-LIFT-R



A-LIFT-CB

Model	Overall Size	Maximum Rated Load	Net Weight
A-LIFT-R	24" x 35" x 68"	500 lb. (227kg)	136 lb. (62kg)
A-LIFT-R-HP	24" x 35" x 68"	400 lb. (182kg)	140 lb. (64kg)
A-LIFT-S	29" x 43" x 68"	500 lb. (227kg)	140 lb. (64kg)
A-LIFT-S-HP	29" x 43" x 68"	400 lb. (182kg)	145 lb. (66kg)
A-LIFT-S-EHP	29" x 43" x 79"	350 lb. (159kg)	154 lb. (70kg)
A-LIFT-CB	29" x 47" x 68"	500 lb. (227kg)	396 lb. (180kg)
A-LIFT-CB-HP	29" x 47" x 68"	400 lb. (182kg)	418 lb. (190kg)
A-LIFT-CB-EHP	29" x 47" x 79"	350 lb. (159kg)	449 lb. (204kg)
A-LIFT-DK (Optional Deck)	20 ¹ / ₂ " x 24 ¹ / ₄ "		25 lb. (11kg)
A-LIFT-PN (Optional 10" pneumatic rear wheels)			20 lb. (9kg)

Receiving instructions:

After delivery, remove the packaging from the product. Inspect the product closely to determine whether it sustained damage during transport. If damage is discovered, record a complete description of it on the bill of lading. If the product is undamaged, discard the packaging.

NOTE:

The end-user is solely responsible for confirming that product design, installation, use, and maintenance comply with laws, regulations, codes, and mandatory standards applied where the product is used.

Table of Contents

Signal Words.....	2
Hazards of Improper Use.....	2
Product specifications by model.....	3
FIG 1A: HP & EHP models have telescoping mast frame.....	3
FIG. 1B: Diagram of Assembled A-Lift.....	4
Assembly Instructions.....	5-7
Operation Instructions.....	7-9
Inspections & Maintenance.....	10
Labeling diagram.....	11
Limited warranty.....	12

Signal Words:

This manual uses SIGNAL WORDS to indicate the likelihood of personal injuries, as well as the probable seriousness of those injuries, if the product is misused in the ways described. Other signal words call attention to uses of the product likely cause property damage. The signal words used appear below along with the meaning of each word:



Identifies a hazardous situation which, if not avoided, **WILL** result in DEATH or SERIOUS INJURY. Use of this signal word is limited to the most extreme situations.



Identifies a hazardous situation which, if not avoided, **COULD** result in DEATH or SERIOUS INJURY.



Indicates a hazardous situation which, if not avoided, **COULD** result in MINOR or MODERATE injury.



Identifies practices likely to result in product/property damage, such as operation that might damage the product.

Hazards of Improper Use:

Vestil strives to identify foreseeable hazards associated with the use of its products. However, no manual can address every conceivable risk. The end-user ultimately is responsible for exercising sound judgment at all times.



If this product is used improperly or carelessly, the operator and/or bystanders might sustain serious personal injuries or even be killed. ALWAYS use the product properly:

- **Failure to read and understand the entire manual before assembling, installing, using or servicing the product might result in misuse.** Read the manual to refresh your understanding of proper use and maintenance procedures.

- ALWAYS inspect the Lifter before each use according to the inspection instructions on p. 10. DO NOT use the Lifter unless it passes the inspection.
- Prior to each use, ALWAYS inspect the area where you intend to use the lifter. Inspect the area for unusual conditions that might require special precautions. See "Notice" on p. 7-8.
- DO NOT use a malfunctioning lifter. Always perform the "Function Test" described in the Notice on p. 8 before each use.
- Regardless of whether the lifter is loaded or unloaded, DO NOT stand or travel under the forks and DO NOT allow any other person to stand or travel under the forks.
- Inform all persons in the area that you are going to use the Lifter, and instruct them to stay clear of the device and the supported load during operation.
- ALWAYS make sure that your clothing and body do not contact the mast structure, lifting mechanisms, or carriage during operation. ONLY operate the lifter from the "Operator's Position," shown in Step 2 on p. 8. DO NOT move the lifter or raise or lower the forks unless you are in the operator's position.
- DO NOT allow people to ride the lifter.
- ALWAYS load the A-lift according to the list of recommendations that appears below. Failure to properly position a load on the forks (or platform) might cause the lifter to tip over and you could be injured as a consequence.
 1. DO NOT exceed the A-Lift's maximum rated load. The rated load (capacity) of your Lifter is posted on a product label as shown in "Labeling diagram" on p. 11.
 2. ONLY move loads using the forks or the optional deck platform ("load-engaging means").
 3. DO NOT handle off-center loads. ALWAYS properly center the load.
 4. Start and stop gradually to avoid upsetting the load from the forks/platform.
 5. NEVER tilt the lifter while carrying a load. All four casters must maintain contact with the ground when a load is on the forks/platform.
- DO NOT modify the lifter in any way UNLESS you first obtain written approval from Vestil. **Unauthorized modifications automatically void the limited warranty (see p. 12) and might make the lifter unsafe to use.**

FIG. 1A: Parts diagram

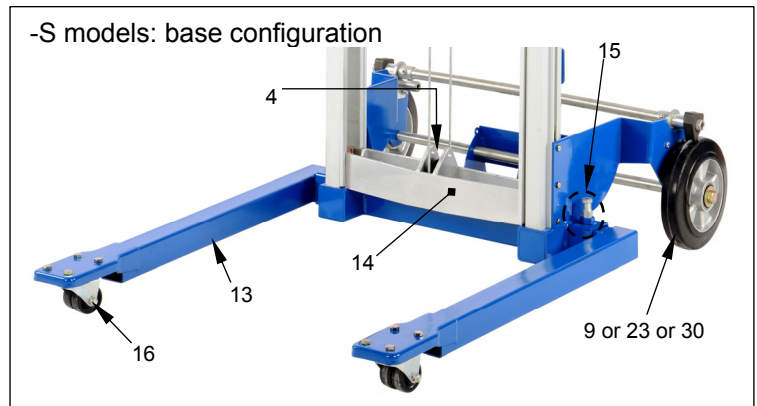
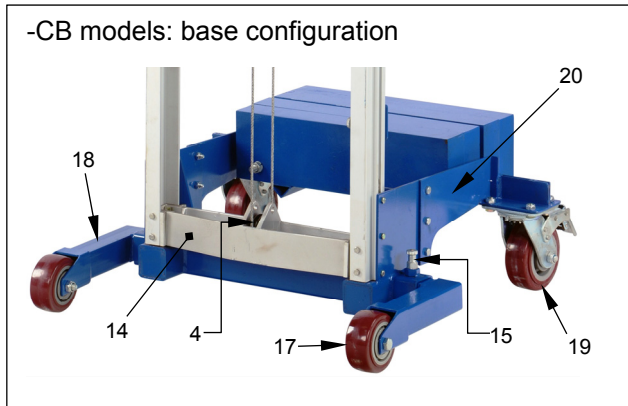
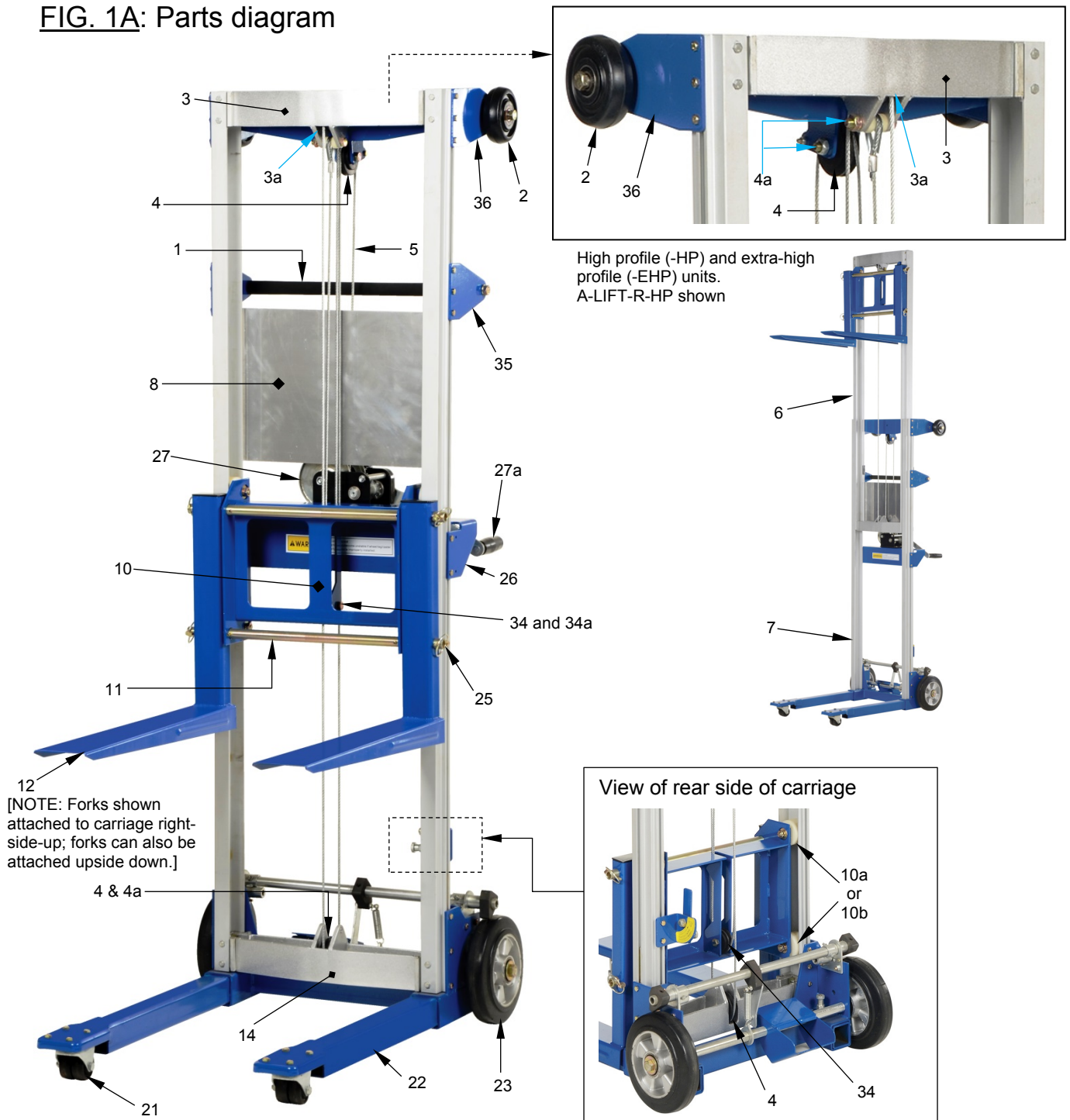

Parts List

“Standard Units” refers to A-Lift-R, -S, & -CB models; “HP Units” means A-Lift-R-HP, -S-HP, and -CB-HP models; “EHP Units” indicates A-Lift-S-EHP and -CB-EHP models.

Item	Description	Part No.	Quantity	Item	Description	Part No.	Quantity
1	Operator Handle	A-Lift-1	1	18	Adjustable Leg (-CB counterweight base models)	A-Lift-CB-18	2
2	Loading Wheels	A-Lift-2	2	19	5 inch Swivel Caster with brake	A-Lift-CB-19	2
3	Upper casting	A-Lift-3	1	20	Counterweight Base	A-Lift-CB-20	1
3a	Inner frame pulley (large)	A-Lift-3a	1				
4	Large Pulley	A-Lift-4	2	21	Caster	A-Lift-R-21	2
4a	Large cable anchor bolt & nut	A-Lift-4a	3				
5	Cable (Standard Units)	A-Lift-5	1	22	Legs - Standard base (R models)	A-Lift-R-22	2
5a	Cable (EHP Units)	A-Lift-EHP-5					
6	Telescoping Inner Mast Frame (only HP & EHP Units)	A-Lift-6	1	23	Solid Rubber Wheel	A-Lift-23	2
7	Mast Frame	A-Lift-7	1	24	Brake (optional)	A-Lift-24	1
8	Decal Plate	A-Lift-8	1	25	Fork Lock Pin	A-Lift-25	4
9	10 in. Pneumatic wheel (optional)	A-Lift-9	2	26	Winch Mounting Bracket	A-Lift-26	1
10a	Carriage rollers 30x41 (EHP models)	A-Lift-R-10a	4	27	Winch	A-Lift-27	1
10b	Carriage rollers 33x55	A-Lift-R-10b	4	27a	Winch Handle	A-Lift-27a	1
				27-SPG	Winch Spring	A-Lift-27-SPG	1
11	Fork Mounting Tube	A-Lift-11	2	28	Not Available	N/A	N/A
12	Fork	A-Lift-12	2	29	Deck (optional)	A-Lift-Deck	1
13	Adjustable Leg (Straddle base)	A-Lift-S-13	2	30	[-S models with 4-point casters] 4in. caster – option A 5in. caster – option B	A-Lift-29A A-Lift-29B	
14	Lower casting	A-Lift-14	1	31-32	Not Available	N/A	N/A
15	Leg Lock Pin	A-Lift-CB-15	2	33	Pivoting carriage latch	A-Lift-33	1
16	Caster	A-Lift-S-16	2	34	Small pulley	A-Lift-34	1
				34a	Small pulley bolt & nut	A-Lift-34a	1
17	4 inch Fixed Wheel	A-Lift-CB-17	2	35	Operator handle bracket	A-Lift-35	2
				36	Load wheel bracket	A-Lift-36	2

Assembly Instructions:

Vestil ships winch lifts to its customers in a mostly assembled form. The minimal assembly that is required differs by model, so follow the directions that correspond to your lifter.

If you purchased an **A-LIFT-R** or **A-LIFT-S**, you will receive 3 pieces:



Support leg receivers

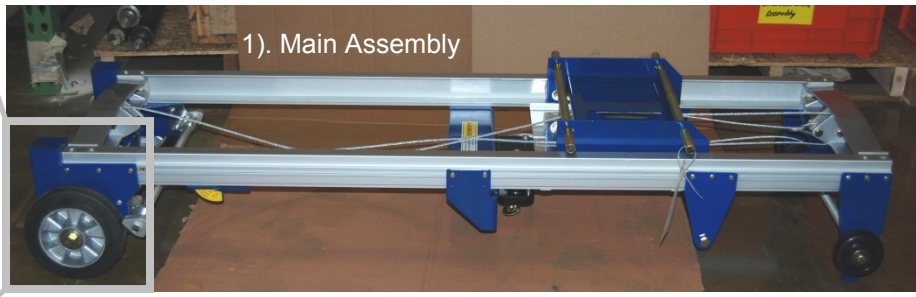

1). Main Assembly

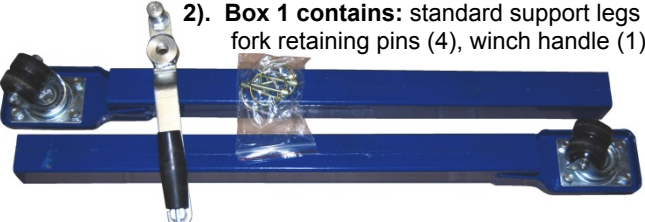

2). **Box 1 contains:** standard support legs (2), fork retaining pins (4), winch handle (1).

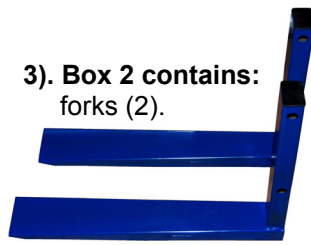

3). **Box 2 contains:** forks (2).

Step 1: Connect the support legs to the main assembly by following instructions (a) through (e).

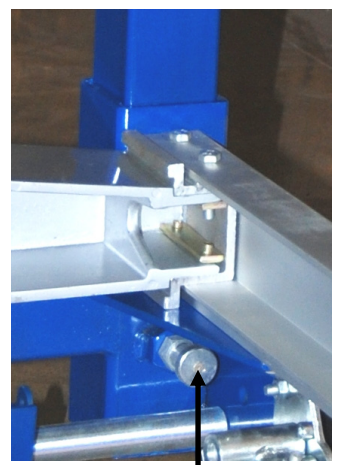

Spring-loaded retaining peg

- (a) Insert a support leg into each of the receivers in the main assembly.
- (b) Pull the retaining pegs to allow the legs to drop to the bottoms of the openings.
- (c) Release the pegs. The pegs should seat into holes in the legs. You might have to wiggle the leg to get the peg to drop.
- (d) Pull up on each support leg to verify that the pegs have seated properly. The legs should not be able to slide out of the opening. If a leg comes out of its receiver, the corresponding peg did not engage properly. Repeat (a) through (d).

Step 2: Lift the assembly to the upright position (photo a). Then, lock the brakes (photo b) and fasten the winch handle to the winch body (photos c – f).



a



b

Engage the brakes by pressing down on the brake actuator

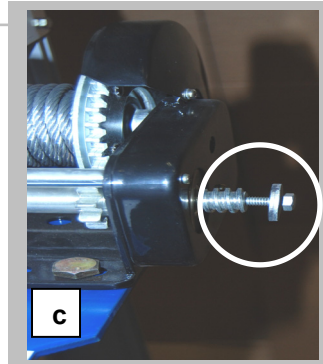

c

Remove the handle retaining bolt and washer (circled)

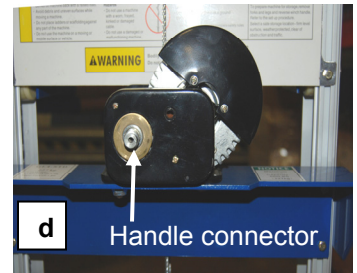

d

Handle connector

Winch body with bolt and washer removed



e

Slide the handle onto the handle connector

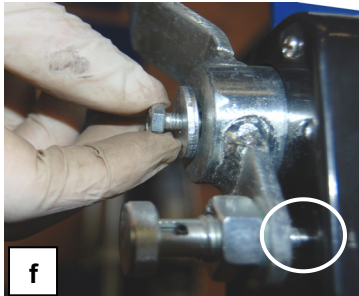

f

Set the handle latch pin (circled) to lock the handle, and then fasten the handle to the handle connector with the bolt and washer that you removed in step (c).

NOTE: Secure the washer against the bolt head with a nut BEFORE fastening the bolt to the connector. This will prevent the bolt from loosening when the handle is rotated counterclockwise to lower the forks.



Step 3: Attach the forks to the carriage.

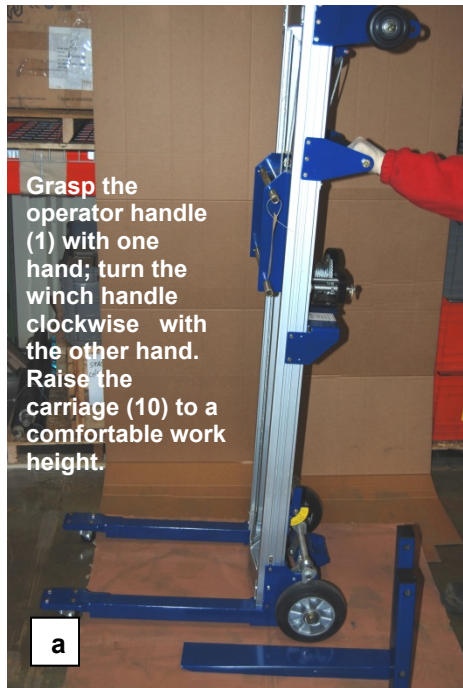

Grasp the operator handle (1) with one hand; turn the winch handle clockwise with the other hand. Raise the carriage (10) to a comfortable work height.

a

b. Align the holes in the forks with the carriage cross- bars (11); then push the forks until they contact the carriage. *Note:* It may be necessary to tap the forks into place with a rubber mallet. **NOTE:** Forks shown installed right side up, but they can also be installed upside down (.

c. Slide fork retaining pins (25) through the holes in each of the carriage crossbars.

d. Lock the pins into place by swinging the ring portion of each pin downward

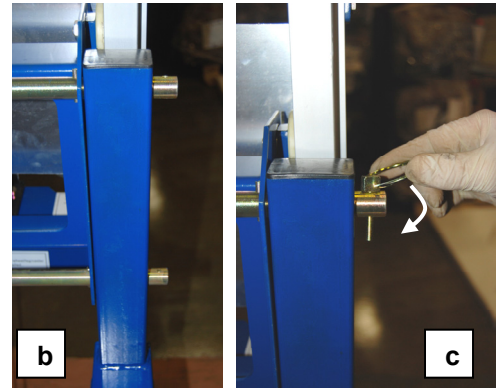

b

c

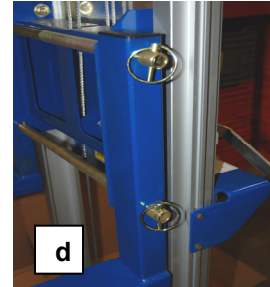

d

Step 4: Turn the winch handle counterclockwise to lower the forks. Lower the forks until they are a few inches above the support legs (22), and then push the lifter to the desired location.

Counterbalanced lifters (A-Lift-CB):

Step 1: Attach the 5 inch swivel casters (19) to the counterweight base weldment (20).

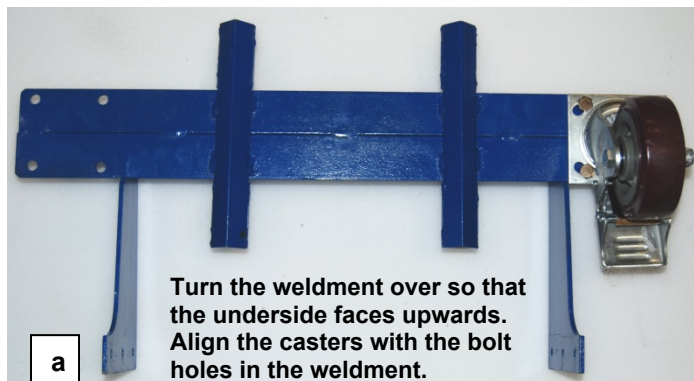

Turn the weldment over so that the underside faces upwards. Align the casters with the bolt holes in the weldment.

a



Lock nut

Bolt

Drop bolts through each of the holes. Secure each bolt with a lock nut. Tighten all of the connections with a pair of wrenches.

b

Step 2: Attach the weldment to the main assembly.

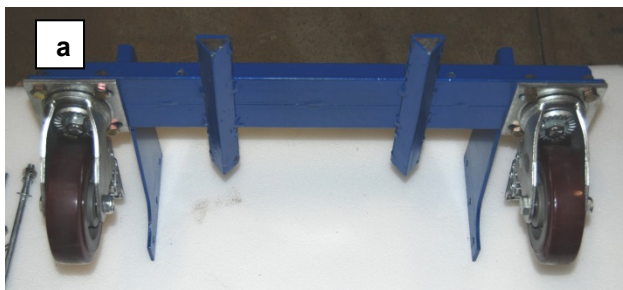

a

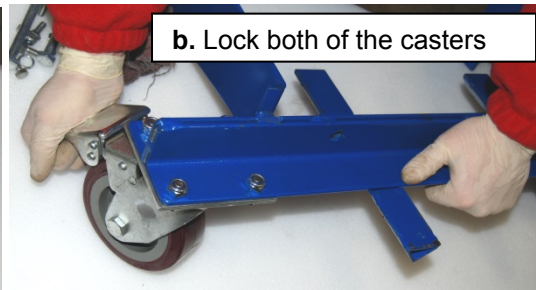

b. Lock both of the casters

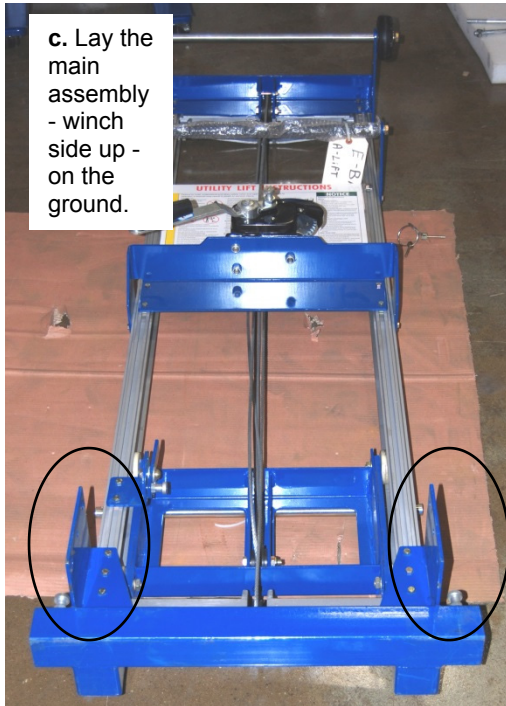

c. Lay the main assembly - winch side up - on the ground.

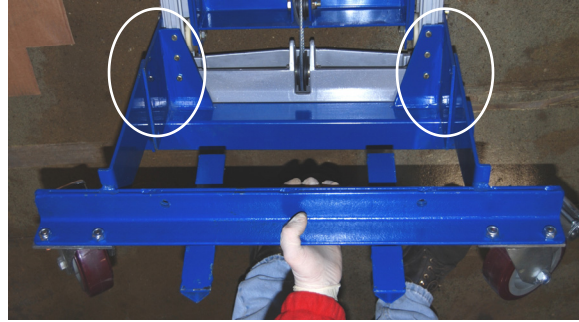

d. Align the bolt holes in the weldment with the holes present in the weldment brackets (circled in photos c & d).

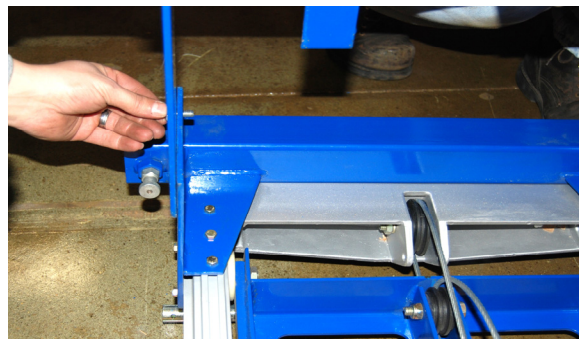

e. Bolt the weldment to the main assembly, and then secure the bolts with nuts.



f. Set the four counterweights on the weldment; then insert the counterweight retaining bolts beginning with the outermost weight.



g. Fasten the bolts in place using a flat washer, followed by a lock washer and then a nut.

Step 3: Install and position the forks by following R & S model fork installation steps 3 & 4 on p. 7.

Operation Instructions:

The operating instructions in this manual are meant to **supplement** the operation recommendations of ITSDF standard B56.10. According to the standard, the A-Lift is a, "Manually propelled high lift industrial truck". Safe operation of this type of device is the operator's responsibility.

WARNING DO NOT operate the winch lift until you read AND understand all of the instructions. If you do not understand an instruction, contact Vestil for clarification.

- Review ALL of the safety guidelines on p. 5 before each use;
- ALWAYS use proper lifting techniques;
- Enlist a coworker to help you lift, load, and unload the A-lift;
- DO NOT use the lifter on stairs.

NOTICE An "Operator" is a person who is trained and authorized to control a manually propelled high lift industrial truck. ONLY persons who have successfully completed the suggested training program outlined in B56.10-2006, at 4.17 on p. 4, and 4.18.1-.4 on p. 4-5 should operate the A-Lift. Operators must:

- Develop safe working habits and an awareness of hazardous conditions occurring or present during operation of the lifter;
- Inspect the area where the lifter will be used **before each use** to identify unusual operating conditions. Implement additional safety precautions as conditions require. Such conditions might include:
 1. Irregularities in the floor/surface;
 2. Debris or other obstructions on the floor/surface;
 3. Unsound surfaces or surfaces that cannot support the weight of yourself, the lifter and the load either together or separately;

- Perform the following **function test before each use**:
 1. Test the winch: raise and lower the forks;
 2. Test the brakes: press down on the brake actuator to engage the brakes; then attempt to push the lift forward.
 3. Test the casters: push the lifter to test the casters.

The end-user bears responsibility for verifying that the lifter complies with all regulations, codes, and standards that apply in the location where it is *used*.

Inspect the lifter as recommended in the “Maintenance and Inspection” section of this manual (p. 10). Use the lifter ONLY IF the lifter passes the inspection and is deemed safe to use by designated inspection personnel.

Step 1 (for S and CB Models): Adjust the legs to provide the desired wheel base. Set the brake (-S models) or lock the casters (-CB models). Remove the forks and lock the carriage using the pivoting carriage latch (photo a). Slowly tilt the lifter backwards until the loading wheels contact the ground. Pull the leg adjustment peg (photo b) and slide the leg in the desired direction. Reset the peg in the first or second adjustment setting (photo c) as the job requires.

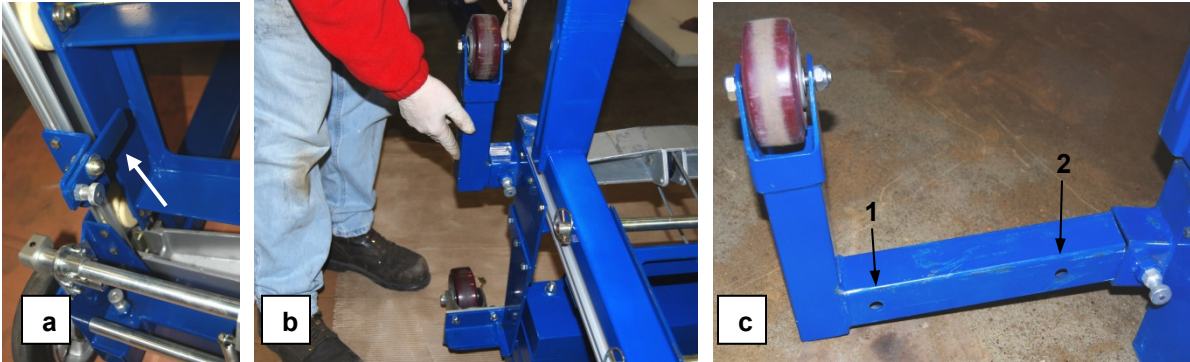

Step 2: Always maneuver the A-lift from the “Operator’s Position” using the Normal Maneuvering Stance shown below.

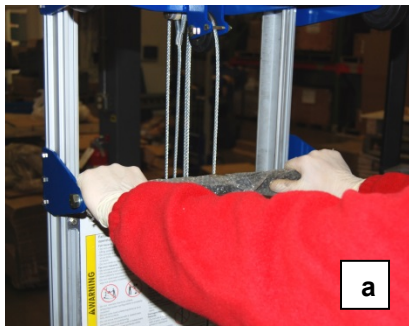

a. Grasp the operator handle at each end. This will provide the greatest degree of steering control.

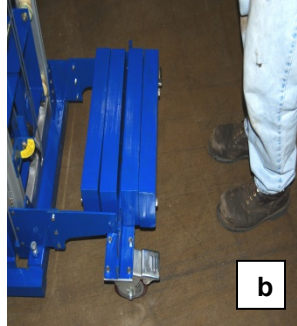

b. Walk behind the lifter and keep your feet clear of the casters.

⚠ WARNING DO NOT place one foot on the counterweights and propel the lifter with the other foot. Doing so will make the lifter more difficult to control.

Step 3: Move the lifter to a position near the intended load and lock both of the locking casters.



Raise the forks to a comfortable height.



Set the load on the forks. The load must rest against the back of the forks.



Lower the forks until the load is a few inches above the adjustable leg (shown by arrow in photo above).

Step 4: Move the load to the desired location.



After you arrive at the unloading destination:

- Lock the castors or set the brakes;
- Unlock the winch handle and turn it clockwise until the load is positioned at a comfortable height;
- Lock the winch handle;
- Remove the load.
- Lower the forks until they are a few inches above the legs.

Step 5: Return the lifter to its storage location. Engage the brakes, fold the winch handle, fully lower the forks, and set the handle latch pin to lock the winch handle

NOTICE Store the lifter in a dry location that is protected from weather.

Using the Deck Platform:

[NOTE: To use the deck, the forks must be attached to the carriage right-side up, as shown below & on p. 3.]



Slide the connecting channel (see arrow) under the lower carriage cross bar.



Set the connecting channel on top of the lower carriage cross bar; let the deck rest on top of the forks.

After you finish using the deck, remove it and store it in a dry location.

Transporting the Lifter:

Before loading the A-lift into a transport vehicle, perform the following steps to minimize the chance of damaging the lifter:

1. Remove the forks and store the forks and fork retaining pins.
2. Lower the carriage completely.
3. Rotate the pivoting carriage latch as shown by photos a & b to the right.

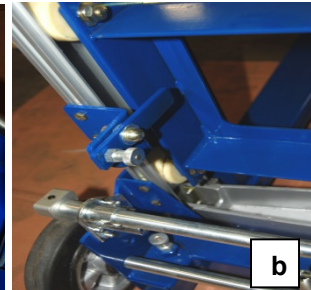
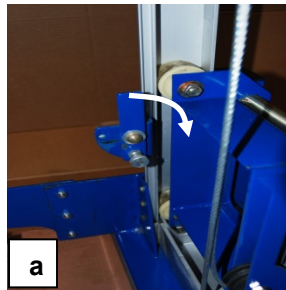

Maintenance and Inspections:

Only trained, authorized persons should inspect of and maintain this device. The end-user is responsible for ensuring that the lifter is properly inspected and maintained.

Inspections:

⚠️WARNING DO NOT use the lifter if structural damage exists. Structural damage includes, but is not limited to, cracked welds, warping or other deformation of the mast, forks, or carriage. Restore the lifter to normal operating condition BEFORE using it again.

Inspection and maintenance personnel should engage the brakes and immobilize the carriage with the pivoting carriage latch before conducting inspections or performing maintenance on the A-Lift.

Persons authorized **by the end-user** to inspect the lifter should do so before it is used for the first time, and before each subsequent use. If the lifter is infrequently used, inspect the unit at least once every 2 weeks.

Before each use, inspect the lifter for the following conditions:

1. Fraying of or damage to the cable, such as a marked decrease in cable diameter;
2. Structural damage or deformation;
3. Proper functioning of the latch mechanism;
4. Unusual noise, binding or rough movement of the carriage when the winch handle is rotated;
5. Excessive wear of any part(s);
6. Noisy or rough operation of the casters;
7. Dirt or other matter on the surface of the lifter.

Maintenance: the end-user should implement a maintenance program to ensure the proper function and safety of the lifter. Some recommended maintenance and inspection procedures appear on pages 8-9 of ANSI/ITSDF standard B56.10-2012 (downloadable at <http://www.itsdf.org/pB56.asp>). The following steps should be utilized in conjunction with those recommendations.

⚠️WARNING The end-user is responsible for selecting and training employees to work on the lifter, i.e. operating, loading, cleaning, servicing, maintaining, or repairing the product. ONLY trained, authorized maintenance personnel or contractors should perform inspection, maintenance, or repair work.

Step 1: Tag the unit, "Out of Service."

Step 2: Conduct a "Before each use" inspection.

- If deformity, corrosion, rusting, or excessive wear of structural members is present, DO NOT use the lifter.
- If the carriage does not move smoothly or makes noise as it moves up or down the mast, apply a silicon wax or silicon spray to the inside of the mast frame.

Step 3: Remove dirt and foreign matter from the surfaces of the forks and other lifter surfaces.

Step 4: Perform all other necessary adjustments and/or repairs, but DO NOT modify the lifter.

NOTES:

- 1) The reader should understand the significant difference between necessary adjustments and repairs, and modifications. "Adjustments" are simple corrections that restore the lifter to normal operating condition, such as tightening loose fasteners, or removing dirt or other debris from surfaces. "Repairs" means to replace worn parts with new parts.
 - DO NOT use the unit if adjustments and/or repairs are incomplete! Return it to service ONLY after finishing all necessary repairs and adjustments.
- 2) A modification is a change that alters the lifter from normal operating condition, like bending the structural members or removing a part or several parts. **NEVER modify the unit without first receiving express, written approval from Vestil. Modifications automatically void the limited warranty and might make the lifter unsafe to use.**

Step 5: Make a dated record of the repairs, adjustments and/or replacements.

Labeling diagram:

Only use the A-Lift if ALL labels are readable and undamaged. Contact Vestil for replacement labels.

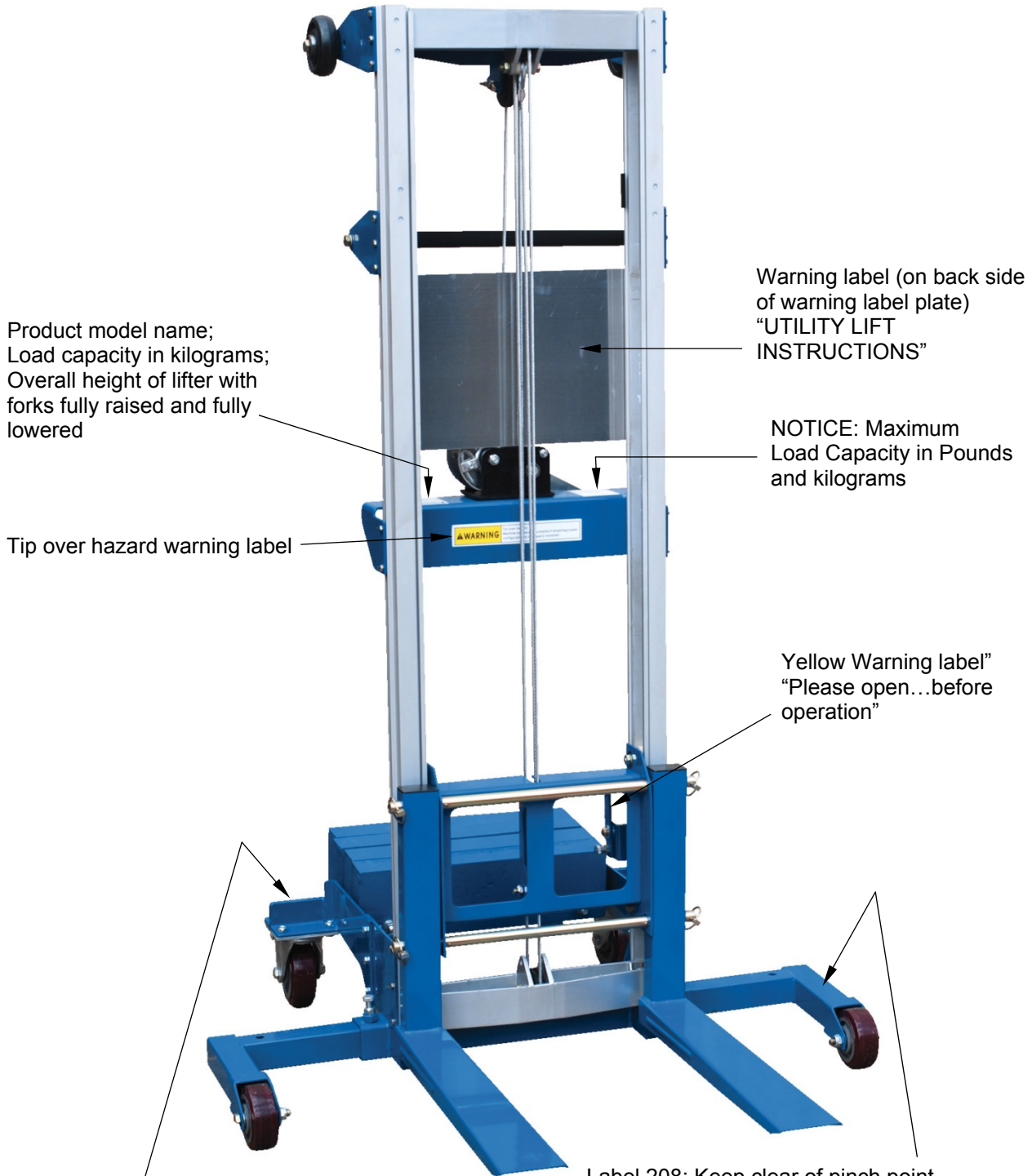

Product model name;
Load capacity in kilograms;
Overall height of lifter with
forks fully raised and fully
lowered

Warning label (on back side
of warning label plate)
"UTILITY LIFT
INSTRUCTIONS"

NOTICE: Maximum
Load Capacity in Pounds
and kilograms

Tip over hazard warning label

Yellow Warning label"
"Please open...before
operation"

Label 208: Keep clear of pinch point

▲ WARNING	▲ ADVERTENCIA	▲ AVERTISSEMENT
KEEP CLEAR OF PINCH POINT	MANTENGASE ALEJADO DEL PUNTO DE CORTE	SE TENIR À DISTANCE DU POINT DE PINCEMENT

Label 212 (on blue cross member close to locking swivel
caster): LOCK CASTER and/or FLOOR LOCK

▲ WARNING	▲ ADVERTENCIA	▲ AVERTISSEMENT
LOCK CASTER and/or FLOOR LOCK when loading and unloading	La RUEDECILLA de la CERRADURA y/o el PISO CIERRAN al cargar y descargar	LOCK CASTER et/ou SOL LOCK lors du chargement et de déchargement

212 Rev 0111

LIMITED WARRANTY

Vestil Manufacturing Corporation (“Vestil”) warrants this product to be free of defects in material and workmanship during the warranty period. Our warranty obligation is to provide a replacement for a defective original part if the part is covered by the warranty, after we receive a proper request from the warrantee (you) for warranty service.

Who may request service?

Only a warrantee may request service. *You are a warrantee if* you purchased the product from Vestil or from an authorized distributor AND Vestil has been fully paid.

What is an “original part”?

An original part is a part used to make the product as shipped to the warrantee.

What is a “proper request”?

A request for warranty service is proper if Vestil receives: 1) a photocopy of the Customer Invoice that displays the shipping date; AND 2) a written request for warranty service including your name and phone number. Send requests by any of the following methods:

<u>Mail</u>	<u>Fax</u>	<u>Email</u>
Vestil Manufacturing Corporation 2999 North Wayne Street, PO Box 507 Angola, IN 46703	(260) 665-1339 <u>Phone</u> (260) 665-7586	sales@vestil.com

In the written request, list the parts believed to be defective and include the address where replacements should be delivered.

What is covered under the warranty?

After Vestil receives your request for warranty service, an authorized representative will contact you to determine whether your claim is covered by the warranty. Before providing warranty service, Vestil may require you to send the entire product, or just the defective part or parts, to its facility in Angola, IN. The warranty covers defects in the following original dynamic components: motors, hydraulic pumps, electronic controllers, switches and cylinders. It also covers defects in original parts that wear under normal usage conditions (“wearing parts”), such as bearings, hoses, wheels, seals, brushes, and batteries.

How long is the warranty period?

The warranty period for original components is 90 days. The warranty period begins on the date when Vestil ships the product to the warrantee. If the product was purchased from an authorized distributor, the period begins when the distributor ships the product. Vestil may extend the warranty period for products shipped from authorized distributors by *up to* 30 days to account for shipping time.

If a defective part is covered by the warranty, what will Vestil do to correct the problem?

Vestil will provide an appropriate replacement for any *covered* part. An authorized representative of Vestil will contact you to discuss your claim.

What is not covered by the warranty?

1. Labor;
2. Freight;
3. Occurrence of any of the following, which automatically voids the warranty:
 - Product misuse;
 - Negligent operation or repair;
 - Corrosion or use in corrosive conditions;
 - Inadequate or improper maintenance;
 - Damage sustained during shipping;
 - Accidents involving the product;
 - Unauthorized modifications: DO NOT modify the product IN ANY WAY without first receiving written authorization from Vestil. Modification(s) might make the product unsafe to use or might cause excessive and/or abnormal wear.

Do any other warranties apply to the product?

Vestil Manufacturing Corp. makes no other express warranties. All implied warranties are disclaimed to the extent allowed by law. Any implied warranty not disclaimed is limited in scope to the terms of this Limited Warranty.

