

# PORTABLE CYLINDER LIFTER - CYL-LT-1-PN

APPROX WEIGHT: 92.56 lbs.  
 DOES NOT INCLUDE WEIGHT OF POWER OR PACKAGING!!!

\*\*\* ANY ADDITIONS, DELETIONS, OR OMISSIONS MUST BE CORRECTED ON THIS DRAWING AS THIS DRAWING WILL BE CONSIDERED ALL INCLUSIVE \*\*\*  
 ALL GRAPHICS PROVIDED ARE FOR REFERENCE ONLY. IF CERTAIN DIMENSIONS ARE CRITICAL PLEASE VERIFY THOSE DIMENSIONS WITH YOUR SALESPERSON

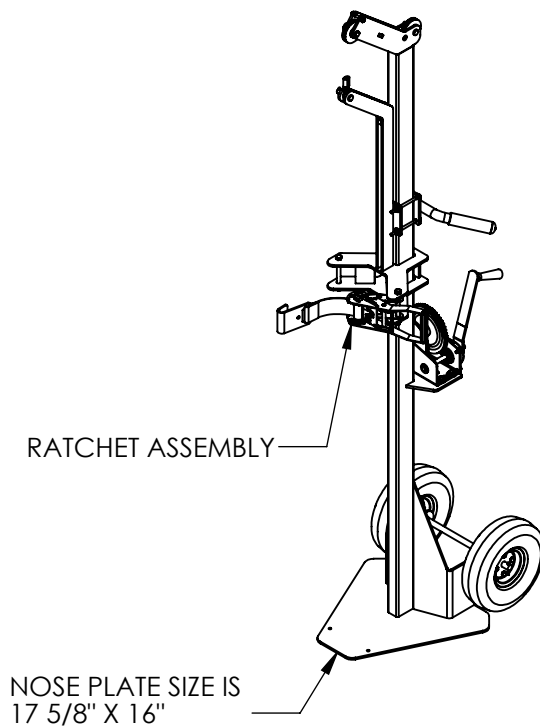
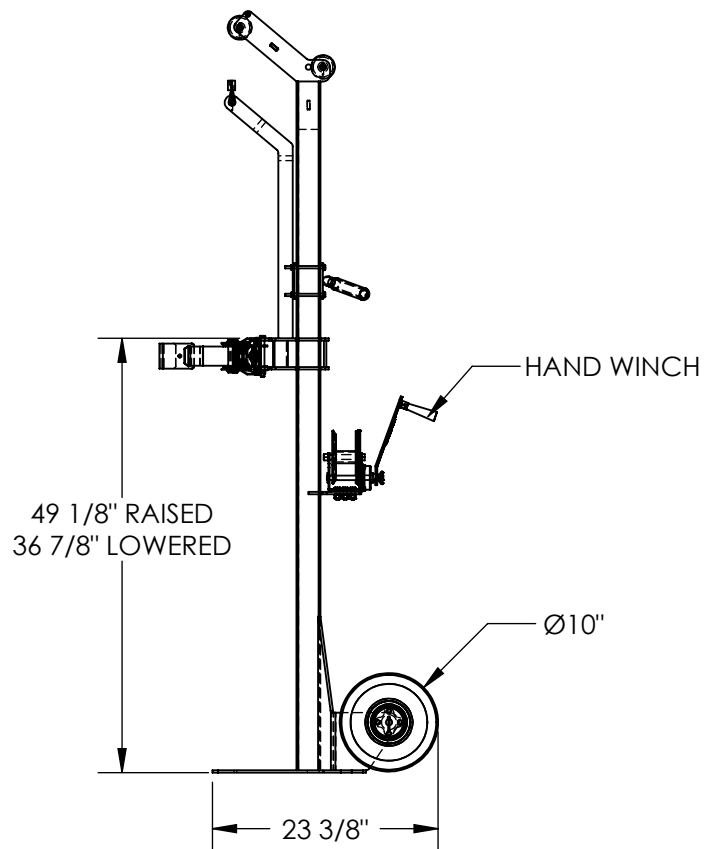
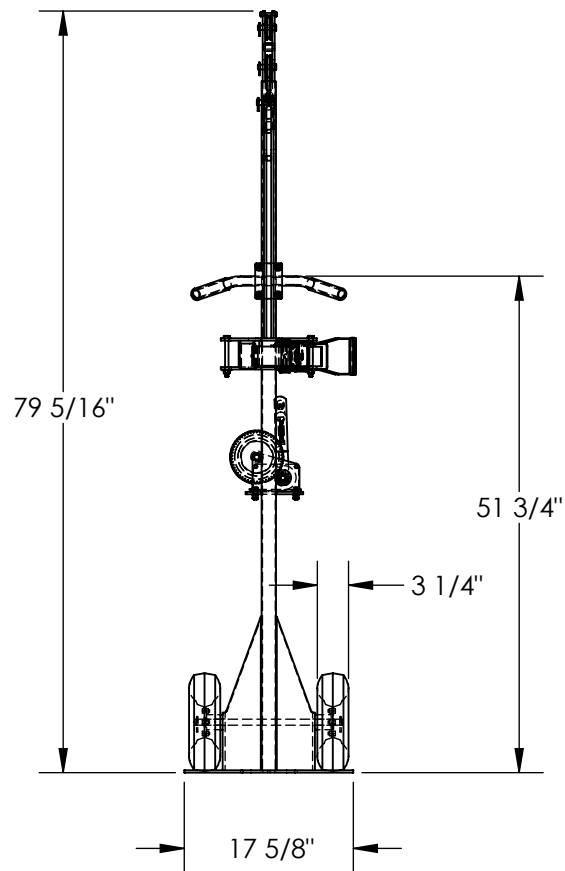

DIMENSION TOLERANCE ± 1/4"

## STANDARD FEATURES

- MODEL NUMBER IS CYL-LT-1-PN
- MAXIMUM CAPACITY IS 300 LBS.
- MAXIMUM CYLINDER DIAMETER IS Ø11 1/2"
- OVERALL WIDTH IS 17 5/8"
- OVERALL DEPTH IS 23 3/8"
- OVERALL HEIGHT IS 79 5/16"
- PNEUMATIC TIRE SIZE IS Ø10" x 3 1/2"
- ADJUSTABLE STRAP RAISED HEIGHT IS 49 1/8"
- ADJUSTABLE STRAP LOWERED HEIGHT 36 7/8"
- HAND WINCH OPERATION
- TOUGH BAKED IN POWDER COATED YELLOW FINISH

## SPECIAL FEATURES

NONE

<b>A P P R O V A L</b>	I, THE UNDERSIGNED, AGREE THAT THE PRODUCT AS REPRESENTED SATISFIES DESIGN AND DIMENSION REQUIREMENTS. I ALSO ACKNOWLEDGE MY DUTY TO CONFIRM PRODUCT AND INSTALLATION COMPLIANCE WITH ALL APPLICABLE FEDERAL, STATE AND LOCAL REGULATIONS AND STANDARDS.	
	<b>ANY MODIFIED UNITS ARE NON-RETURNABLE</b>	
	[ ] As drawn      [ ] As marked	
	Signed: _____ Date: _____	
Printed Name: _____		
<b>LEAD TIME WILL START UPON RECEIPT OF SIGNED APPROVAL DRAWING</b>		

FOR INTERNAL USE ONLY PROJECT SIGN OFF	
SALES	
ENG.	
FAB.	
POWER	

DISTRIBUTOR'S NAME:		P.O.#
<b>VESTIL MANUFACTURING</b>		X
		W.O.#
DRAWN BY: J.RIDLEY	DATE: 03/21/09	X
REFERENCE: X	SCALE: 1:20	FILE NAME:
QUOTED LEAD TIME: X	QUOTE # X	16-007-195