

SLNM-118-AA (Narrow Mast Semi-Electric Stacker with Adjustable Legs and Adjustable Forks)

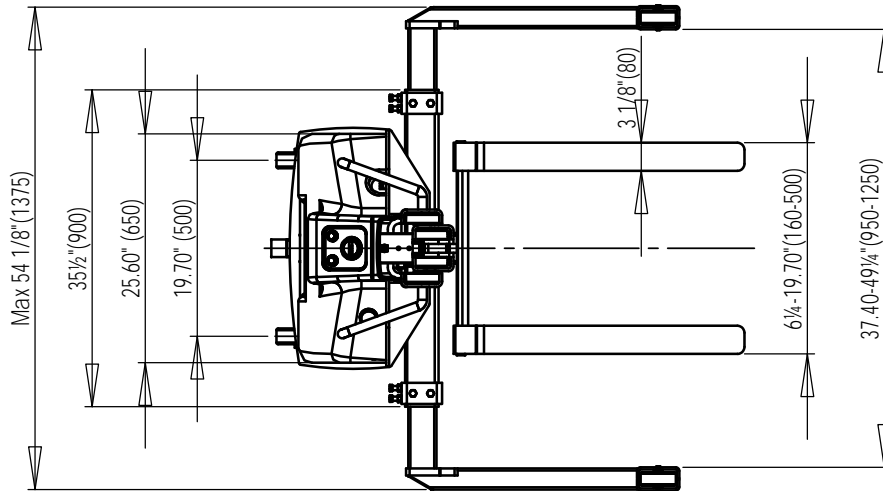
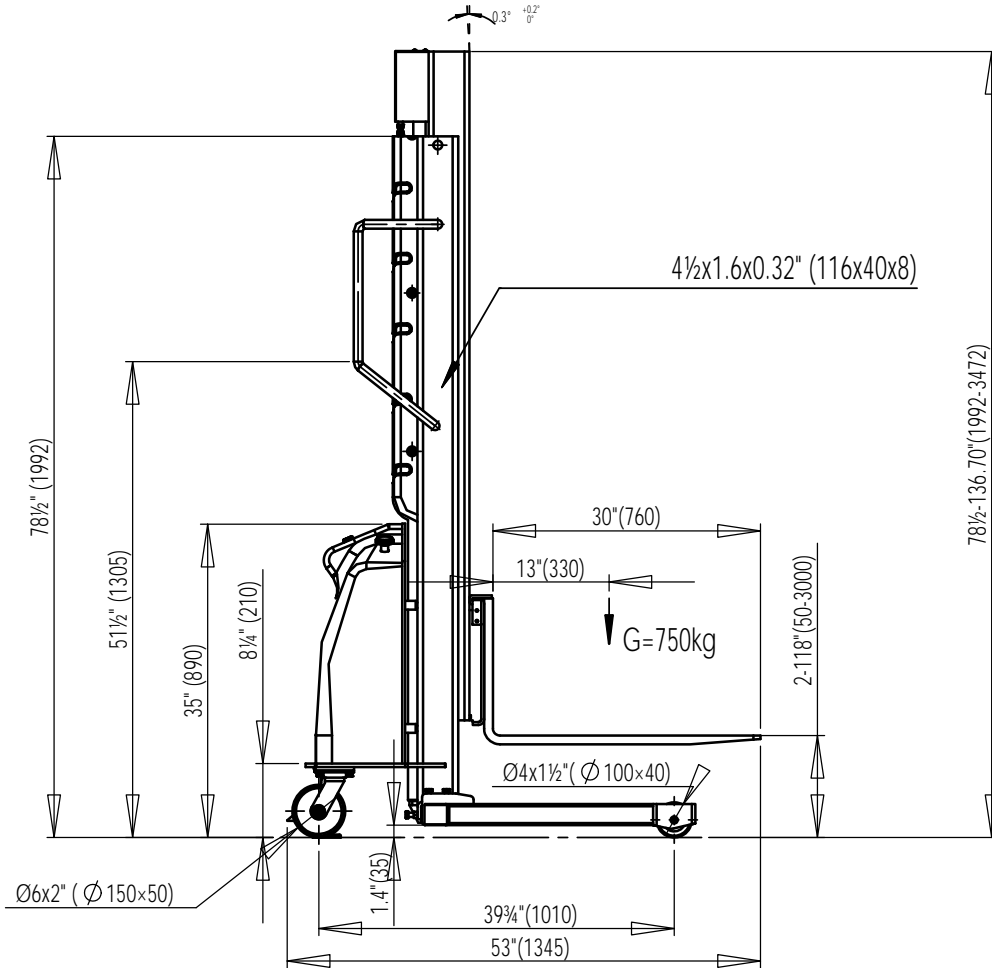

Specifications

Model # SLNM-118-AA
 Capacity (UDL): 1,500 lbs (680 kgs)
 Lift Height: 118" (3000mm)
 Lowered Height: 2" (50mm)
 Adjustable Forks and Adjustable Legs
 Overall Mast Height: 78 1/2" (1920mm)
 Lift Motor: DC12V/1.3KW
 Battery: 12V/140Ah
 Battery Charger: 12V/6amp

Raise Time Loaded: 5.9"/s
 Raise Time Unloaded: 2.95"/s
 Downtime Loaded: 4"/s
 Downtime Unloaded: 3.15"/s

VESTIL MANUFACTURING CORP	
Model:	SLNM-118-AA
Descrip:	Narrow Mast Semi-Electric Stacker with Adjustable Forks and Adjustable Legs
Design:	T.M
Date:	02/22/13